

**SINGER**  
**5102/5107/5123/5127**

# SINGER\*

+ Sub CLASSES

## LIST OF PARTS FOR SEWING MACHINES

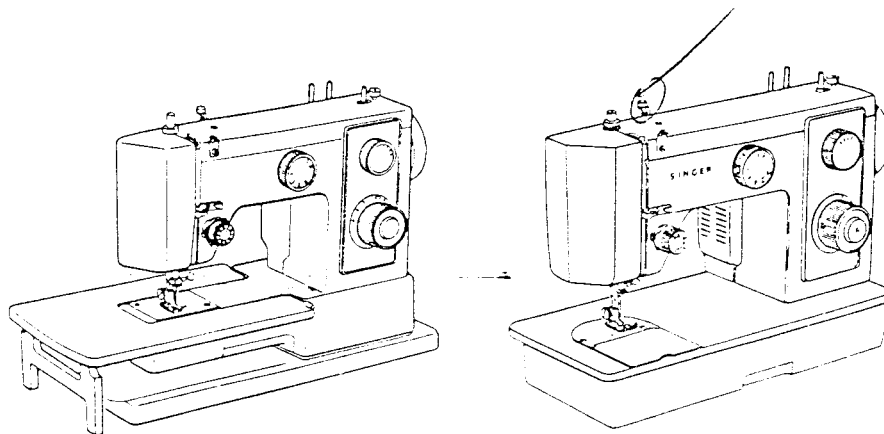

# 5100 SERIES

Copyright © 1980 THE SINGER COMPANY  
All Rights Reserved Throughout the World



\*A Trademark of THE SINGER COMPANY

TABLE OF TERRITORIES

COUNTRY	MOTOR	CONTROLLER WITH LABEL	LIGHT HARNESS
U. S. A.	988215-001 988236-001 (ALT.) (120 V)	988216-001 (120 V)	988279-001
	988217-001	988218-001	
CANADA	988215-001 988236-001 (ALT.) (120 V)	988295-001 (120 V)	988279-001
	988217-001	988218-001	
YUGOSLAVIA, IRAN, NEW ZEALAND, SOUTH AFRICA, ISRAEL, GERMANY, AUSTRIA, FRANCE, ITALY, PORTUGAL, GREECE	988217-002 (220 V)	988218-002 (220 V)	988227-001
NETHERLAND, BELGIUM, SWITZERLAND	988217-002 (220 V)	988218-002 (220 V)	988227-001
UNITED KINGDOM	988217-003 (240 V)	988218-004 (240 V)	988227-001
AUSTRALIA	988217-003 (240 V)	988218-005 (240 V)	988227-001
GERMANY	988217-002 (220 V)	988218-002 (220 V)	988227-001
EUROPE-NON MANDATORY	988217-002 (220 V)	988218-002 (220 V)	988227-001
AUSTRIA	988217-002 (220 V)	988218-002 (220 V)	988227-001
DENMARK	988217-002 (220 V)	988218-003 (220 V)	988227-001
SWEDEN, NORWAY, FINLAND	988217-002 (220 V)	988218-002 (220 V)	988227-001

<u>MECHANISM DESCRIPTION</u>	<u>PAGE</u>
ATTACHMENT SET	4
MACHINE COVERS	5
SELECTOR DIALS AND PANELS	8
SHUTTLE AND SHUTTLE DRIVE ASSEMBLIES	9
FEED MECHANISM	12
HEAD END MECHANISM	13
ARM SHAFT AND NEEDLE THREAD TENSION ASSEMBLIES	16
CAM CONTROL MECHANISM	17, 20, 21
ELECTRICAL EQUIPMENT	24



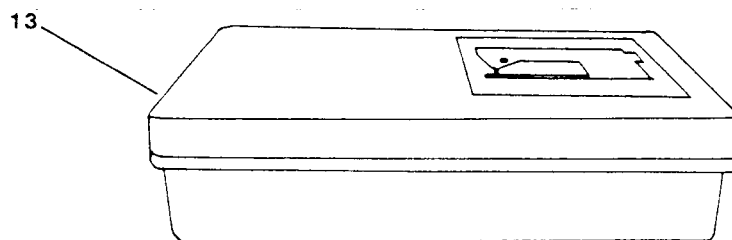
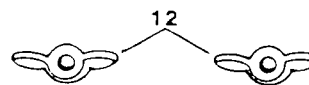
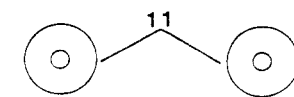
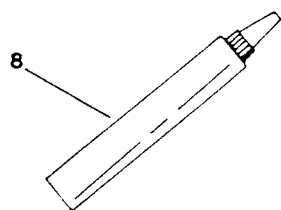
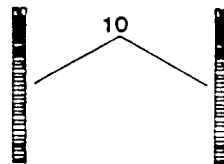
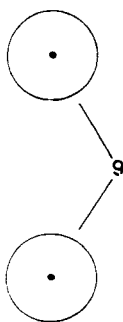
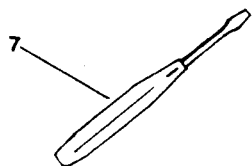
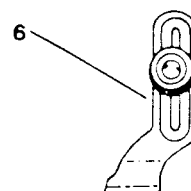
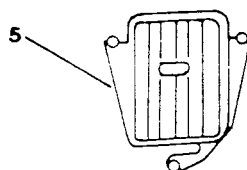
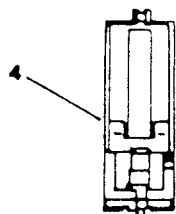
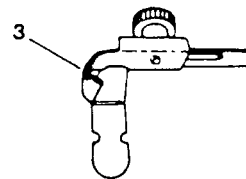
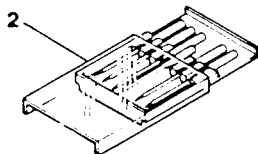
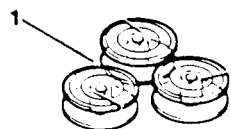

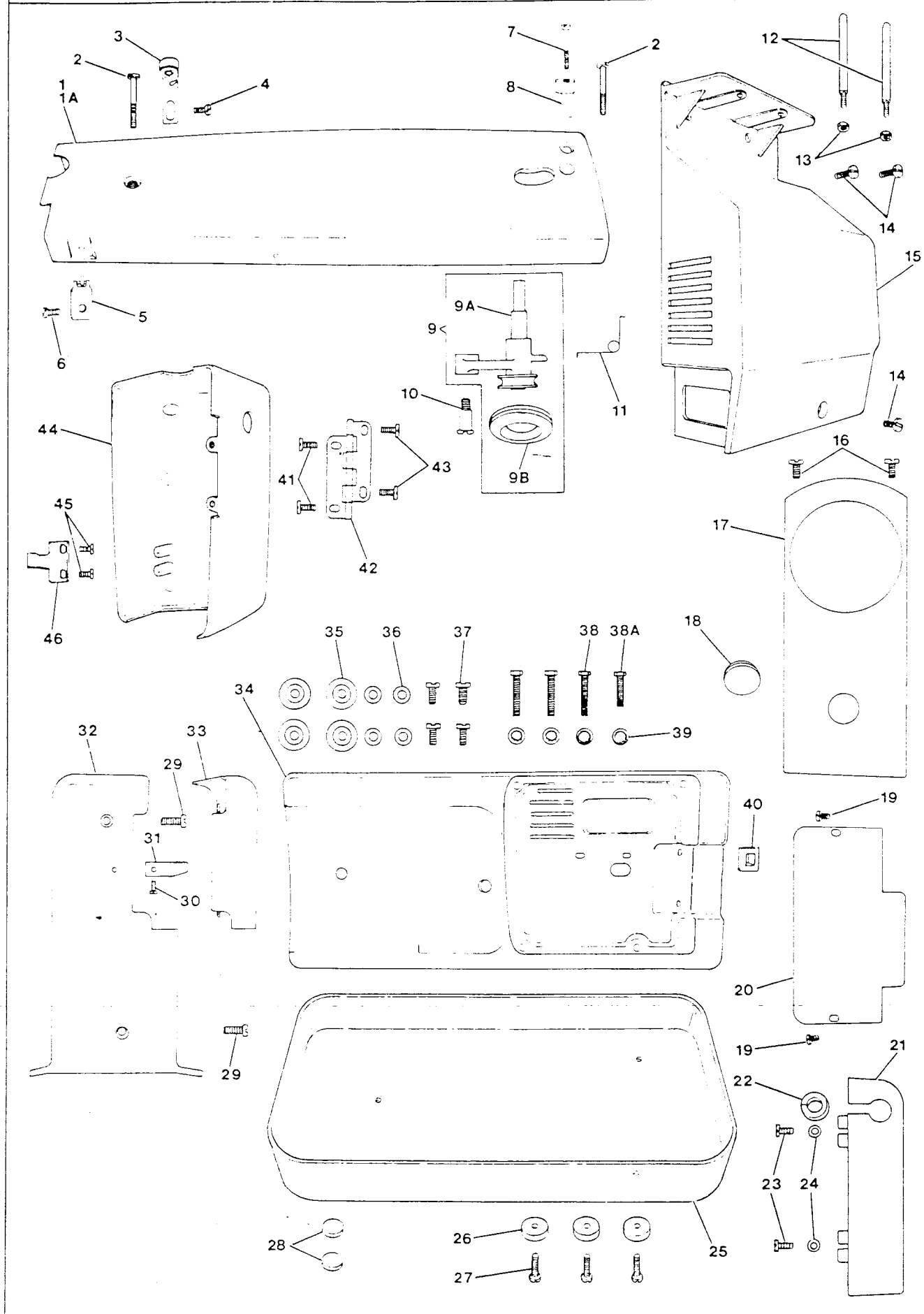

From the library of: Diamond Needle Corp

## 5100 PARTS LIST

REF.	PART #	MACHINE COVERS	5102	5107	5123	5127
1A	170395-001	Arm top cover	X		X	
1	170395	Arm top cover		X		X
2	170392	Upper plate set screw (2)	X	X	X	X
3	170396	Thread guide (rear) >	X	X	X	X
4	170396-001	Thread guide screw	X	X	X	X
5	170397	Upper thread guide >	X	X	X	X
6	170539	Thread guide screw	X	X	X	X
7	170393	Set screw	X	X	X	X
8	170394	Bobbin winder stopper	X	X	X	X
9	170243	Bobbin winder complete	X	X	X	X
9A	170243-001	Bobbin winder bracket	X	X	X	X
9B	170520	Bobbin winder ring	X	X	X	X
10	170244	Bobbin winder bracket screw	X	X	X	X
11	170245	Bobbin winder frame spring	X	X	X	X
12	170541	Spool pin	X	X	X	X
13	170542	Spool pin nut	X	X	X	X
14	170432	Set screw (3)	X	X	X	X
15	170431	Motor cover with spool pin	X	X	X	X
16	170410	Set screw (2)	X	X	X	X
17	170411	Rear arm cover	X	X	X	X
18	170351	Plastic filler plug (large)			X	X
19	170426	Set screw (2)			X	X
20	170425	Rear bed cover			X	X
21	170510	Bed extension plate	X	X		
22	170511	Bed extension plate grommet	X	X		
23	170513	Set screw	X	X		
24	170512	Washer	X	X		
25	170508	Bottom cover	X	X		
26	170514	Bottom cover cushion (large) (3)	X	X		
27	170515	Set screw (2)	X	X		
28	170509	Bottom cover cushion (small) (2)	X	X		
29	170377	Set screw (2)			X	X
30	170375	Set screw			X	X
31	170374	Spring			X	X
32	170376	Button plate			X	X
33	170373	Shuttle race cover			X	X
34	170378	Base			X	X
35	170381	Rubber protector (4)			X	X
36	170380	Washer (4)			X	X
37	170382	Set screw (4)			X	X
38	170543	Base screw (long) (3)	X	X	X	X
38A	170544	Base screw (short)	X	X	X	X
39	170545	Base screw washer (4)	X	X	X	X
40	170379	Base grommet			X	X
41	170404	Set screw (2)	X	X	X	X
42	170403	Face plate hinge	X	X	X	X
43	170405	Set screw (2)	X	X	X	X
44	170400	Face cover	X	X	X	X
45	170402	Set screw (2)	X	X	X	X
46	170401	Face cover spring	X	X	X	X



5100 PARTS LIST

REF.	PART #	SELECTOR DIALS AND PANELS	5102	5107	5123	5127
1	170417	Stitch length dial	X			
1A	170417-001	Stitch length dial		X		
1B	170417-002	Stitch length dial			X	X
2	170287	Spring		X	X	X
3	170418	Stitch length dial set screw (2)	X	X	X	X
4	170285	Reverse button	X			
4A	170285-001	Reverse button		X		
4B	170285-002	Reverse button			X	X
5	170286	Set screw	X	X	X	X
6	170420	Pattern selector dial		X		
6A	170420-001	Pattern selector dial			X	
6B	170420-002	Pattern selector dial				X
7	170407	Pattern selector dial set screw (2)	X	X	X	X
8	170406	Stitch width dial	X			
8A	170406-001	Stitch width dial		X		
8B	170406-002	Stitch width dial			X	X
9	170546	Nut	X	X	X	X
10	170547	Stitch width dial set screw (2)	X	X	X	X
11	170409	Control panel			X	X
12	170408	Snap ring			X	X
13	170390	Retaining plate			X	X
14	170391	Set screw			X	X
15	170387	Cloth plate leg			X	X
16	170389	Set screw (2)			X	X
17	170388	Spring (2)			X	X
18	170386	Cloth plate			X	X
19	148844-451	Filler plate			X	X
19A	148845-451	Filler plate			X	X

From the library of: Diamond Needle Corp

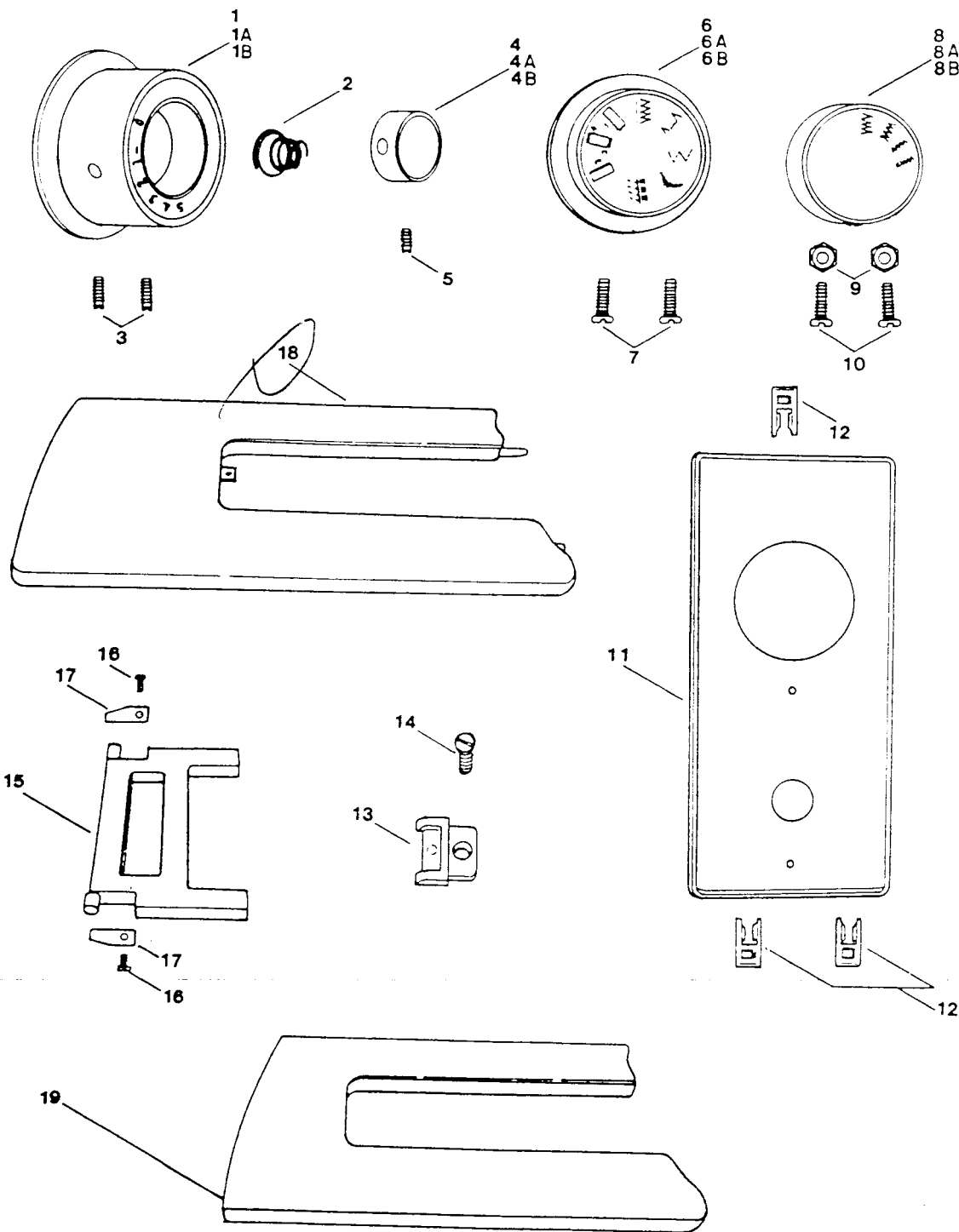

From the library of: Diamond Needle Corp

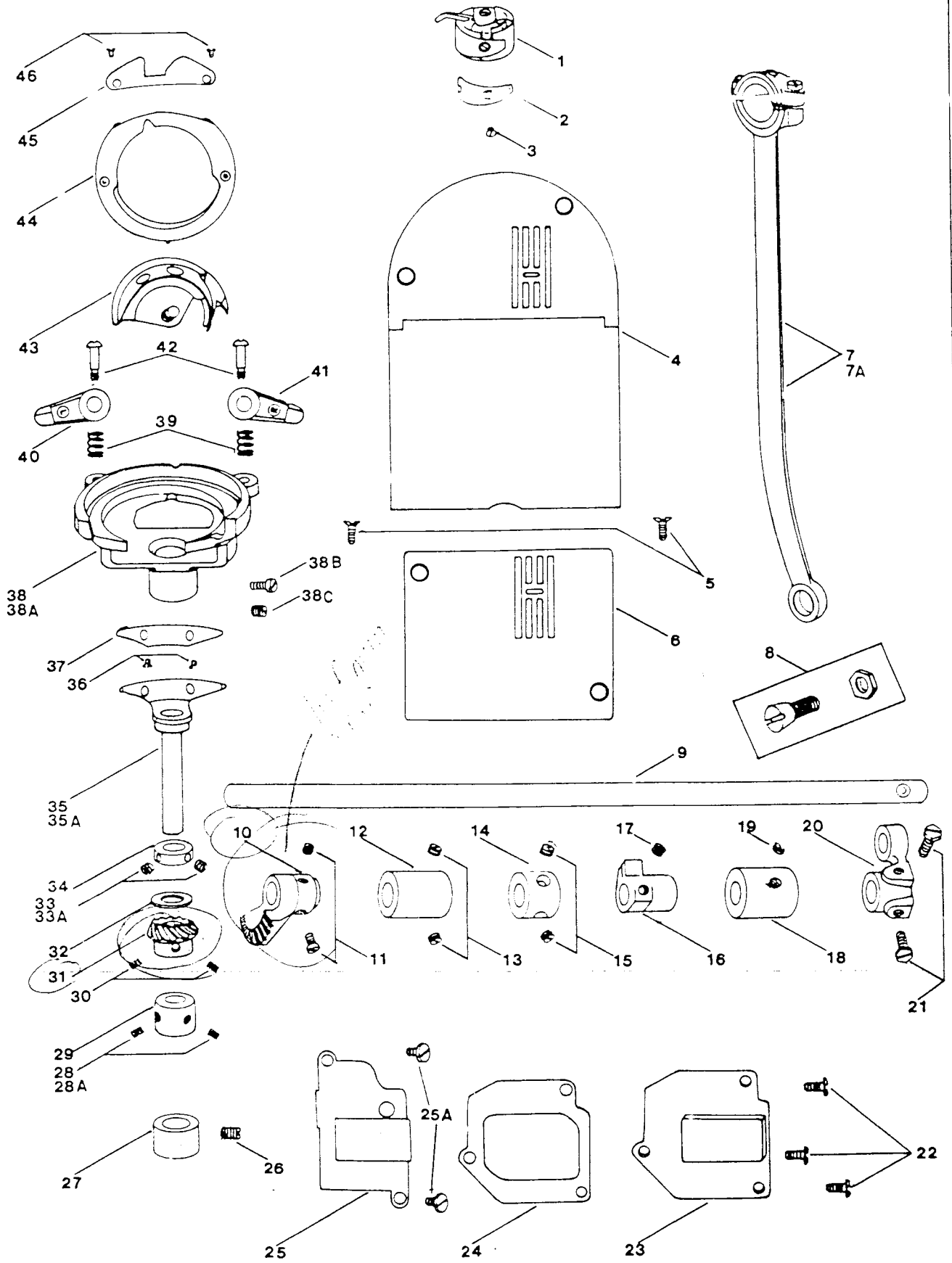

From the library of: Diamond Needle Corp

## 5100 PARTS LIST

REF.	PART #	SHUTTLE/SHUTTLE DRIVE ASSEMBLIES	5102	5107	5123	5127
1	170341	Bobbin case complete	X	X	X	X
2	170518	Tension spring	X	X	X	X
3	170519	Tension spring screw	X	X	X	X
4	170487	Needle & hinged slide plate	X	X		
5	170314	Needle plate screw	X	X	X	X
6	170313	Needle plate			X	X
7	170272	Crank connecting rod			X	X
7A	170506	Crank connecting rod	X	X		
8	170273	Taper screw & nut	X	X	X	X
9	170362	Oscillating shaft	X	X	X	X
10	170352	Gear (large) - <i>half moon gear</i>	X	X	X	X
11	170355	Gear set screw	X	X	X	X
12	170354	Shaft bushing	X	X	X	X
13	170353	Oscillating shaft bushing set screw (2)	X	X	X	X
14	170356	Oscillating shaft collar	X	X	X	X
15	170357	Oscillating shaft collar set screw (2)	X	X	X	X
16	170358	Oscillating shaft cam	X	X	X	X
17	170359	Oscillating shaft cam set screw	X	X	X	X
18	170361	Oscillating shaft metal	X	X	X	X
19	170360	Oscillating shaft metal set screw	X	X	X	X
20	170363	Oscillating shaft crank	X	X	X	X
21	170364	Set screw (2)	X	X	X	X
22	170494	Set screw for gear box cover (3)	X	X	X	X
23	170495	Gear box cover	X	X		
24	170493	Fiber gasket	X	X		
25	170371	Gear box cover			X	X
25A	170372	Set screw			X	X
26	170486	Set screw	X	X		
27	170485	Shuttle driver shaft	X	X		
28	170348	Shuttle driver shaft collar set screw (2)			X	X
28A	170484	Shuttle driver shaft collar set screw (2)	X	X		
29	170483	Shuttle driver shaft collar	X	X		
30	170350	Set screw	X	X	X	X
31	170349	Gear	X	X	X	X
32	170548	Shuttle driver shaft collar washer	X	X	X	X
33	170348	Shuttle driver shaft collar set screw (2)			X	X
33A	170484	Shuttle driver shaft collar set screw (2)	X	X		
34	170347	Shuttle driver shaft collar			X	X
35	170346	Shuttle driver and shaft			X	X
35A	170482	Shuttle driver and shaft	X	X		
36	170527	Shuttle driver spring screw	X	X	X	X
37	170526	Shuttle driver spring	X	X	X	X
38	170343	Shuttle race			X	X
38A	170481	Shuttle race	X	X		
38B	170549	Shuttle race set screw			X	X
38C	170550	Shuttle race set screw	X	X	X	X
39	170525	Shuttle race latch screw spring (2)	X	X	X	X
40	170551	Shuttle race latch (left)	X	X	X	X
41	170552	Shuttle race latch (right)	X	X	X	X
42	170553	Shuttle race latch screw (2)	X	X	X	X
43	170340	Shuttle	X	X	X	X
44	170554	Shuttle race gate	X	X	X	X
45	170521	Shuttle race cap	X	X	X	X
46	170522	Shuttle race cap screw	X	X	X	X

5100 PARTS LIST

REF.	PART #	FEED MECHANISM	5102	5107	5123	5127
1	170332	Snap ring			X	X
2	170331	Shaft			X	X
3	170327	Feed dog set screw (2)	X	X	X	X
4	170328	Feed dog			X	X
4A	170496	Feed dog	X	X		
5	170329	Feed bracket			X	X
6	170497	Feed bracket	X	X		
7	170365	Feed lifting rock shaft crank			X	X
8	170366	Set screw	X	X	X	X
9	170367	Feed bar crank shaft			X	X
10	170369	Oscillating shaft cam crank			X	X
11	170368	Set screw	X	X	X	X
12	170270	Feed regulator stud	X	X	X	X
13	170269	Feed forked connecting slide block	X	X	X	X
14	170268	Feed forked connection 1			X	X
14A	170504	Feed forked connection	X	X		
15	170271	Feed forked connection			X	X
15A	170505	Taper screw & nut	X	X		
16	170275	Feed adjusting screw	X	X	X	X
17	170276	Nut	X	X	X	X
18	170274	Stitch regulator support plate	X	X	X	X
19	170277	Set screw	X	X	X	X
20	170278	Feed regulator	X	X	X	X
21	170279	Snap ring	X	X	X	X
22	170288	Stitch length mechanism		X	X	X
22A	170507	Stitch length mechanism	X			
23	170289	Set screw	X	X	X	X
24	170498	Oscillating shaft crank	X	X		
25	170370	Spring	X	X	X	X
26	170368	Set screw	X	X	X	X
27	170555	Feed lifting rock shaft	X	X		
28	170556	Crank screw	X	X		
29	170499	Feed lifing rock shaft crank	X	X		
30	170492	Feed rock shaft center screw & nut (2)	X	X		
31	170503	Spring	X	X		
32	170501	Set screw	X	X		
33	170502	Spring plate	X	X		
34	170491	Feed rock shaft	X	X		
35	170500	Feed rock shaft rod crank	X	X		
36	170339	Set screw	X	X	X	X
37	170489	Feed bracket shaft	X	X		
38	170488	Snap ring	X	X		
39	170336	Feed rock shaft center	X	X		
40	170337	Feed rock shaft center	X	X		
41	170335	Set screw	X	X		
42	170334	Feed rock shaft	X	X		
43	170330	Set screw	X	X	X	X
44	170333	Feed bracket spring	X	X		
45	170338	Feed rock shaft crank	X	X		

From the library of: Diamond Needle Corp

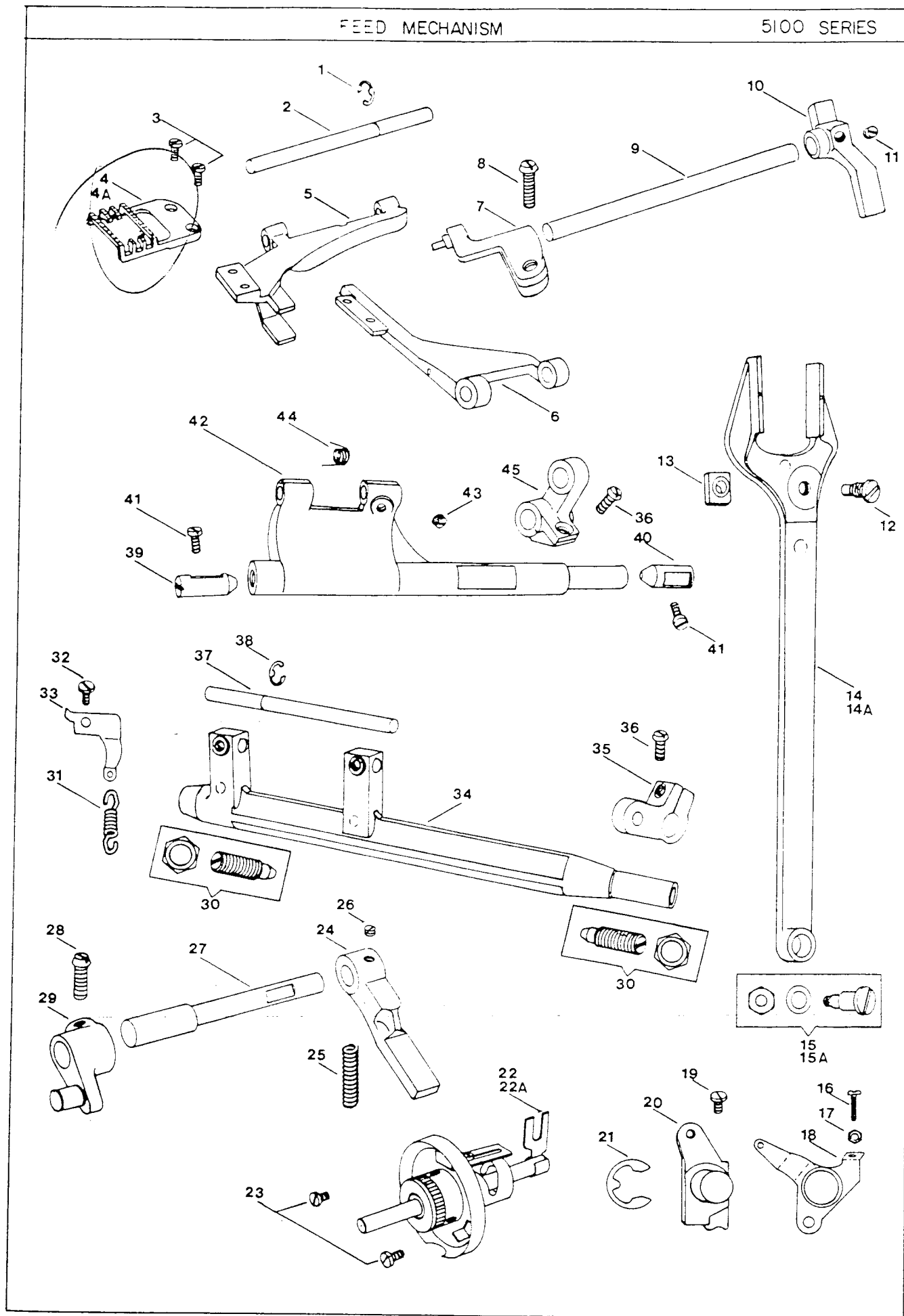

From the library of: Diamond Needle Corp

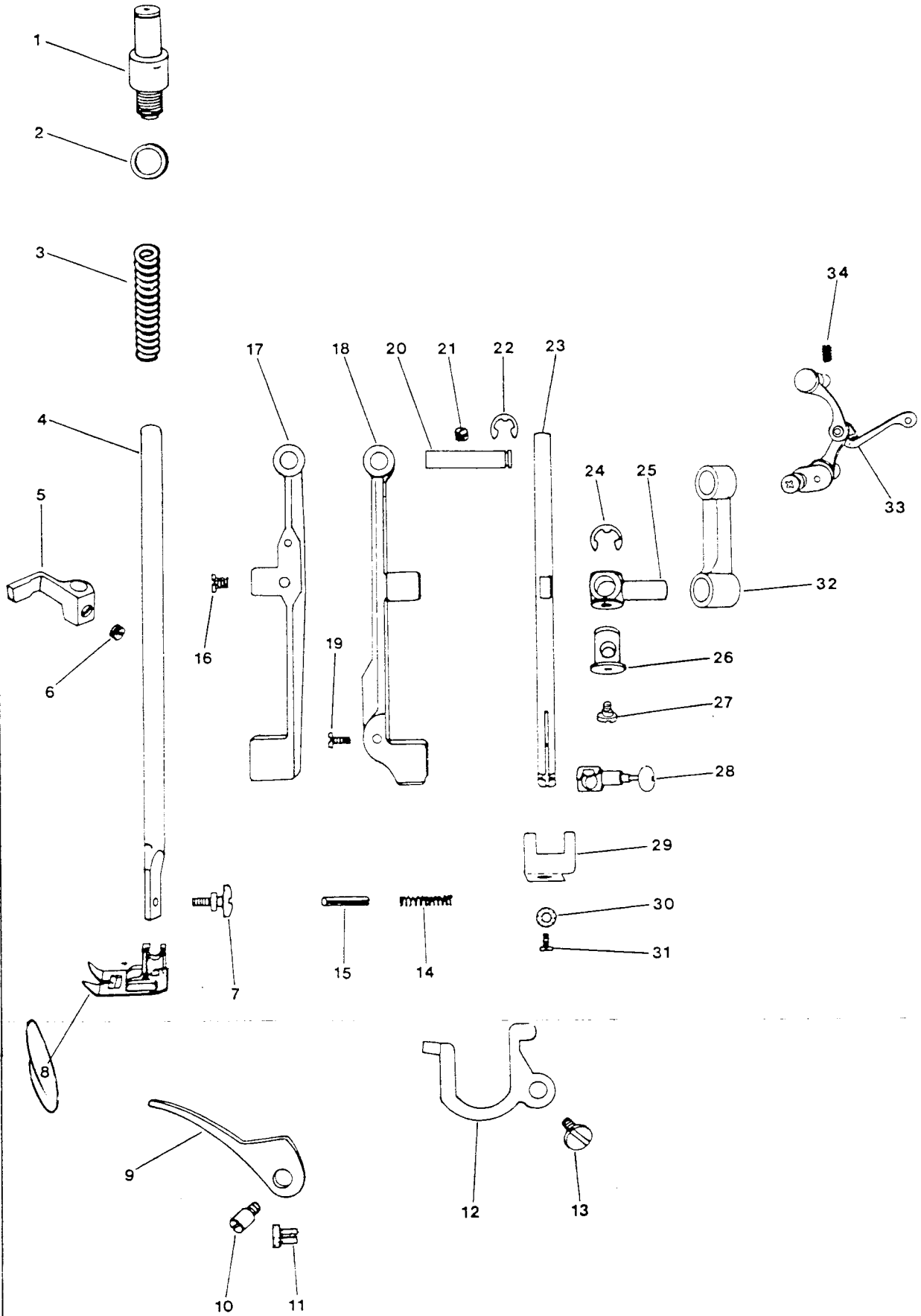

From the library of: Diamond Needle Corp

5100 PARTS LIST

REF.	PART #	HEAD END MECHANISM	5102	5107	5123	5127
1	170290	Presser release mechanism	X	X	X	X
2	170557	Presser bar release mechanism washer	X	X	X	X
3	170292	Presser bar spring	X	X	X	X
4	170291	Presser bar	X	X	X	X
5	170294	Presser bar slide	X	X	X	X
6	170295	Set screw	X	X	X	X
7	170293	Presser foot set screw	X	X	X	X
8	170323	Presser foot	X	X	X	X
9	170296	Presser bar lifter	X	X	X	X
10	170297	Presser bar lifter hinge stud	X	X	X	X
11	170304	Presser bar lifter cushion	X	X	X	X
12	170300	Tension release lever	X	X	X	X
13	170301	Tension release lever set screw	X	X	X	X
14	170318	Spring	X	X	X	X
15	170319	Set pin	X	X	X	X
16	170317	Set screw	X	X	X	X
17	170316	Needle bar supporter		X	X	X
18	170480	Needle bar supporter	X			
19	170558	Needle bar supporter screw			X	X
20	170307	Needle bar supporter shaft	X	X	X	X
21	170305	Needle bar supporter shaft set screw	X	X	X	X
22	170306	Snap ring	X	X	X	X
23	170320	Needle bar	X	X	X	X
24	170308	Snap ring	X	X	X	X
25	170326	Needle bar holder	X	X	X	X
26	170309	Needle bar supporter pin		X	X	X
27	170325	Set screw	X	X	X	X
28	170321	Needle clamp	X	X	X	X
29	170310	Needle bar bracket stop	X	X	X	X
30	170311	Washer	X	X	X	X
31	170312	Set screw	X	X	X	X
32	170324	Needle bar crank	X	X	X	X
33	170204	Thread take-up lever	X	X	X	X
34	170205	Thread take-up lever screw	X	X	X	X

From the library of: Diamond Needle Corp



5100 PARTS LIST

REF.	PART #	ARM SHAFT & NEEDLE THREAD TENSION ASSY.	5102	5107	5123	5127
1	170248	Arm shaft	X	X	X	X
2	170259	Thread take-up holder	X	X	X	X
3	170260	Crank pin set screw	X	X	X	X
4	170261	Thread take-up holder spring pin	X	X	X	X
5	170257	Arm shaft bushing	X	X	X	X
6	170258	Set screw	X	X	X	X
7	170255	Arm shaft collar	X	X	X	X
8	170256	Set screw (2)	X	X	X	X
9	170253	Arm shaft gear	X	X		
9A	170479	Arm shaft gear			X	X
10	170254	Set screw (2)	X	X	X	X
11	170251	Feed cam	X	X	X	X
12	170252	Feed cam set screw	X	X	X	X
13	170249	Flanged bushing	X	X	X	X
14	170250	Set screw	X	X	X	X
15	170246	Hand wheel bushing	X	X	X	X
16	170247	Hand wheel bushing taper pin	X	X	X	X
17	170283	Clamp stop motion screw	X	X	X	X
18	170282	Clamp stop motion stop screw	X	X	X	X
19	170284	Clamp stop motion washer	X	X	X	X
20	170281	Hand wheel	X	X	X	X
21	170398	Arm thread guide (upper)	X	X	X	X
22	170399	Set screw	X	X	X	X
23	170302	Tension dial	X			
23A	170302-001	Tension dial		X		
23B	170302-002	Tension dial <i>comp</i>			X	X
24	170523	Take-up spring	X	X	X	X
25	170303	Tension dial set screw	X	X	X	X
26	170298	Thread guide & Face plate lock	X	X	X	X
27	170299	Thread guide set screw	X	X	X	X

From the library of: Diamond Needle Corp

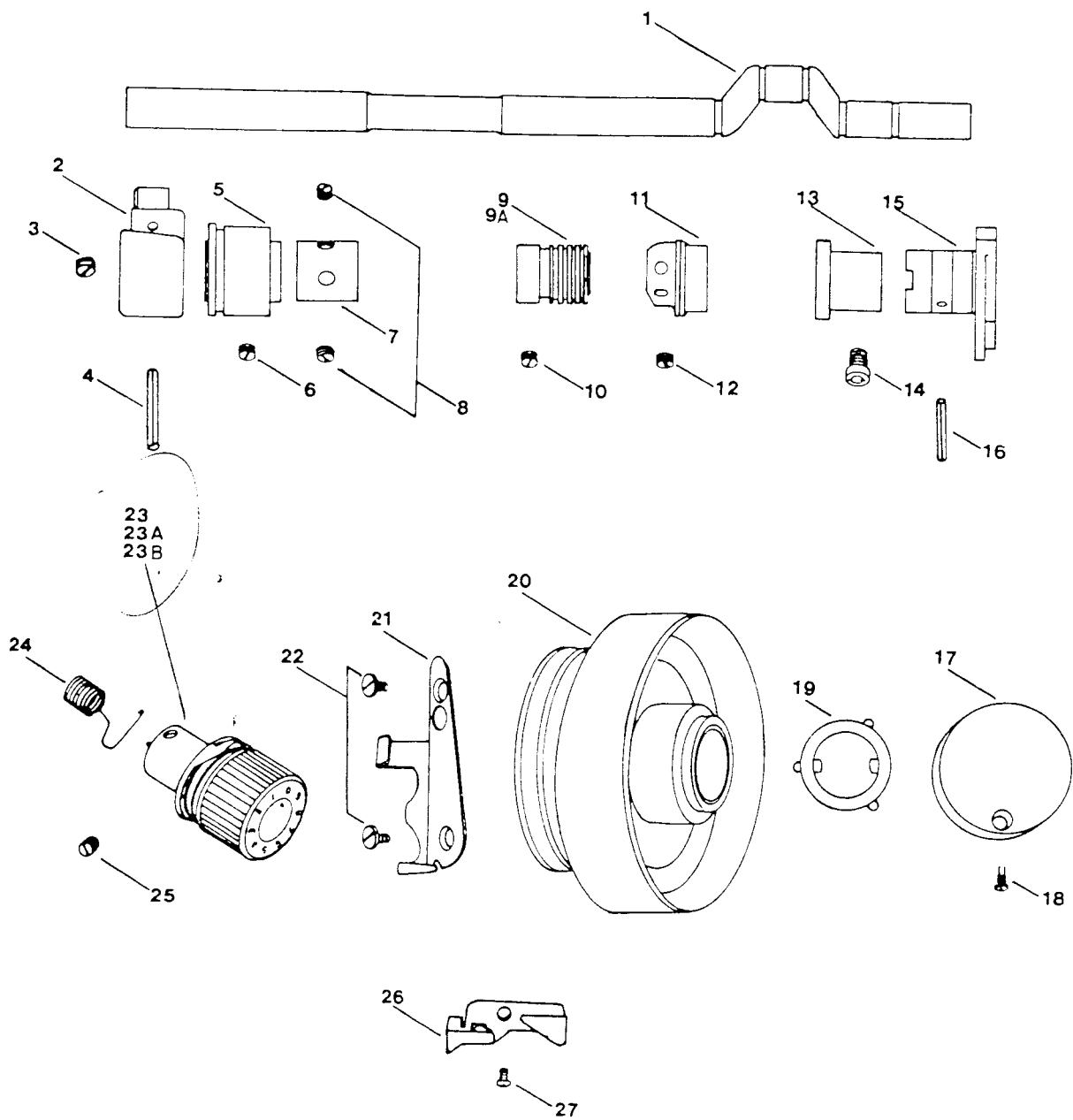

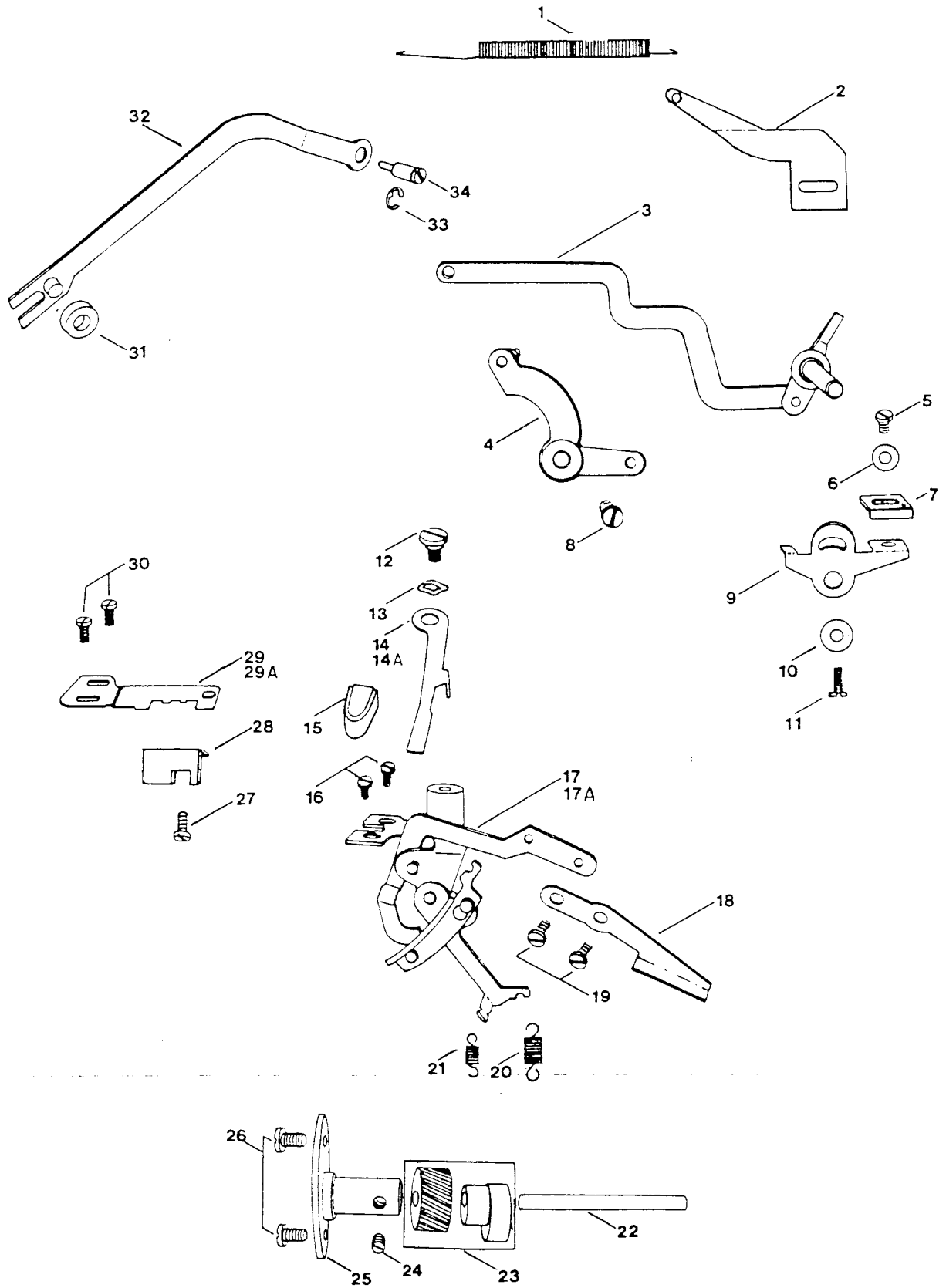

From the library of: Diamond Needle Corp

5100 PARTS LIST

REF.	PART #	CAM CONTROL MECHANISM (A)	5102	5107	5123	5127
1	170538	Cam follower spring				
2	170322	Spring plate			X	
3	170463	Stitch width connecting lever			X	
4	170472	Stitch width crank	X			
5	170469	Set screw	X			
6	170467	Washer	X			
7	170468	Bight position stopper	X			
8	170473	Set screw	X			
9	170464	Stitch width stopper	X			
10	170466	Washer	X			
11	170465	Set screw	X			
12	170478	Set screw	X			
13	170477	Spring washer	X			
14	170475	Needle position lever	X			
14A	170446	Needle position lever				
15	170476	Needle position lever knob	X		X	
16	170448	Set screw	X			
17	170449	Zig-zag mechanism complete	X			
17A	170447	Zig-zag mechanism complete				
18	170461	Zig-zag mechanism correct plate			X	
19	170462	Set screw (2)	X			
20	170450	Spring	X			
21	170456	Needle bar oscillating plate spring	X			
22	170459	Cam shaft	X			
23	170452	Bight cam	X			
24	170453	Set screw	X			
25	170454	Plate	X			
26	170455	Set screw	X			
27	170423	Set screw				
28	170424	Needle position stopper			X	
29	170471	Needle position plate			X	
29A	170445	Needle position plate	X			
30	170470	Set screw (2)			X	
31	170458	Plastic washer	X			
32	170457	Stitch width needle bar crank lever	X			
33	170559	Snap ring	X	X	X	X
34	170460	Eccentric pin	X			

From the library of: Diamond Needle Corp

5100 PARTS LIST

REF.	PART #	CAM CONTROL MECHANISM (B)	5102	5107	5123	5127
1	170198	Set screw		X		X
2	170194	Buttonhole connecting lever		X		X
3	170197	Reverse stitch connecting plate spring		X		X
4	170196	Snap ring		X		X
5	170195	Connecting plate supporter		X		X
6	170199	Reverse stitch connecting plate		X		X
7	170264	Nut (small)		X		X
8	170263	Nut (large)		X		X
9	170265	Spring		X		X
10	170262	Connecting bar for reverse patterns		X		X
11	170266	Set screw		X		X
12	170267	Feed regulator spring (A)		X		X
13	170280	Feed regulator spring	X	X		X
14	170237	Set screw		X	X	X
15	170236	Zig-zag connecting plate		X		X
16	170239	Spring washer (2)	X	X		X
17	170238	Zig-zag connecting plate		X		X
17A	170240	Washer		X	X	X
18	170241	Pin stud		X		X
19	170242	Nut	X	X		X
20	170200	Needle bar connecting plate		X		X
21	170201	Set screw		X		X
22	170460	Eccentric pin	X			
23	170211	Snap ring	X			
24	170516	Connecting link screw			X	
25	170530	Washer			X	
26	170517	Nut			X	
27	170531	Snap ring			X	
28	170474	Cam follower connecting link			X	
29	170189	Needle bar oscillating plate		X		X
30	170191	Ndle. bar oscillating correcting pl. spring		X		X
31	170237	Set screw		X	X	X
32	170193	Adjusting screw		X		X
33	170192	Adjusting nut		X		X
34	170187 †	Oscillating plate fitting plate		X		X
35	170188	Set screw (2)		X		X
36	170190	Snap ring		X		X

From the library of: Diamond Needle Corp

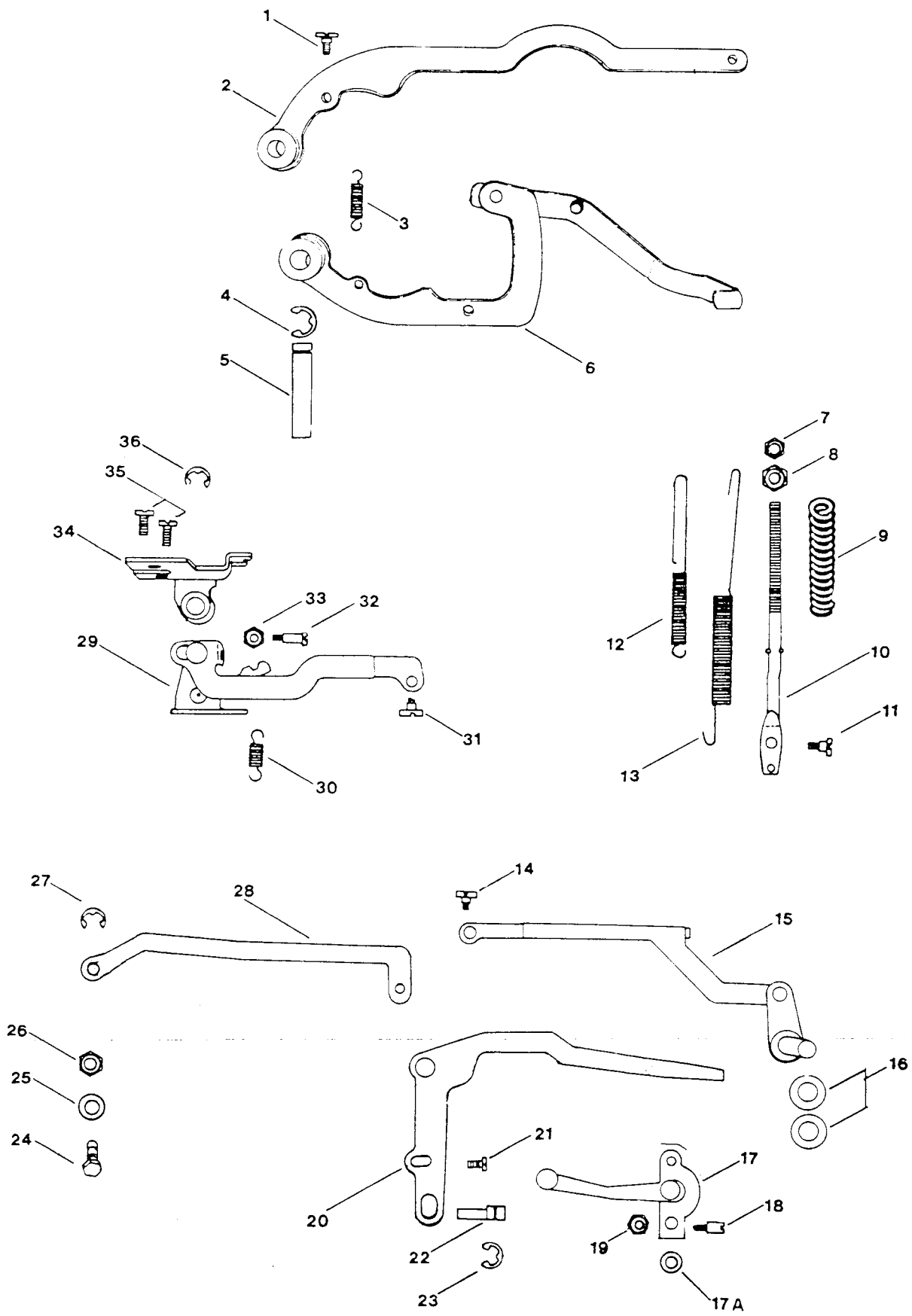

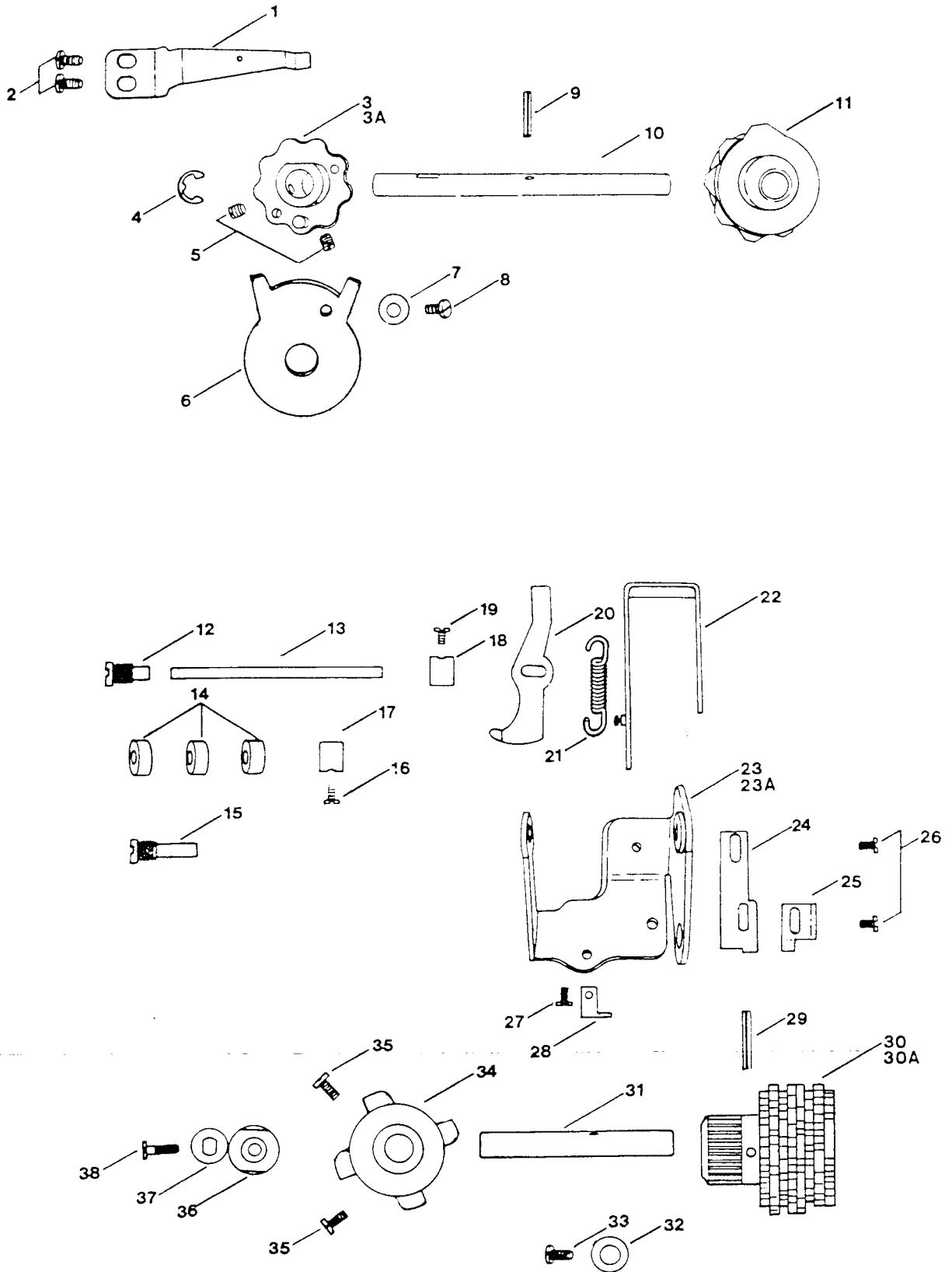

## 5100 PARTS LIST

REF.	PART #	CAM CONTROL MECHANISM (C)	5102	5107	5123	5127
1	170202	Detent spring		X		X
2	170203	Set screw (2)		X		X
3	170224	Pattern detent plate		X		(X)
3A	170529	Pattern detent plate			X	
4	170451	Snap ring	X			
5	170225	Set screw (2)		X		X
6	170532	Straight stitch position stopper			X	
7	170534	Stopper washer			X	
8	170533	Stopper screw			X	
9	170229	Pattern cam selector shaft pin		X		X
10	170223	Shift cam shaft		X		X
11	170228	Pattern cam selector		X		(X)
12	170221	Set screw		X		X
13	170219	Cam follower shaft		X		X
14	170537	Collar (3)			X	
15	170218	Cam follower shaft screw		X		X
16	170536	Collar screw			X	
17	170537	Collar			X	
18	170220	Cam follower shaft stop collar		X		X
19	170536	Set screw		X		X
20	170217	Cam follower		X	X	X
21	170222	Cam follower spring		X		X
22	170216	Cam follower supporting bracket		X		X
23	170206	Pattern cam device bracket		X		X
23A	170342	Pattern cam device bracket			X	
24	170212	Bight position stopper (larger)		X		X
25	170214	Bight position stopper (small)		X		X
26	170213	Set screw (2)		X		X
27	170210	Set screw		X		X
28	170209	Spring plate		X		X
29	170231	Pattern cam shaft pin		X		X
30	170230	Pattern cam			X	
30A	170528	Pattern cam		X		(X)
31	170235	Pattern cam shaft		X		X
32	170208	Washer		X		X
33	170207	Set screw		X		X
34	170226	Flexi cam ✓		X		X
35	170227	Set screw (2)		X		X
36	170234	Flexi cam shaft collar		X		X
37	170233	Adjusting washer		X		X
38	170232	Set screw		X		X



5100 PARTS LIST

REF.	PART #	ELECTRICAL EQUIPMENT	5102	5107	5123	5127
1		Brush cap	X	X	X	X
2		Brush cap insert	X	X	X	X
3		Brush with spring	X	X	X	X
4		Set screw	X	X	X	X
5		Motor pulley	X	X	X	X
6		Washer	X	X	X	X
7		Nylon spacer	X	X	X	X
8		Nylon washer	X	X	X	X
9		Nut	X	X	X	X
10		Motor mounting bracket	X	X	X	X
11	988215-001	Motor (120 Volt)	X	X	X	X
11	988217-001	Motor (120 Volt) (Alternate)	X	X	X	X
11	988217-002	Motor (220 Volt)	X	X	X	X
11	988217-003	Motor (240 Volt)	X	X	X	X
12	170437	Motor belt	X	X	X	X
13	170439	Motor set screw washer	X	X	X	X
14	170438	Motor set screw spring washer	X	X	X	X
15	170440	Motor set screw	X	X	X	X
16	170436	Cord grommet	X	X	X	X
17	<del>988216-001</del>	Controller (120 Volt) <i>Be-volt</i>	X	X	X	X
17	988218-001	Controller (120 Volt) (Alternate)	X	X	X	X
17	988295-001	Controller (120 Volt) Canada	X	X	X	X
17	988218-002	Controller (220 Volt)	X	X	X	X
17	988218-003	Controller (220 Volt)	X	X	X	X
17	988218-004	Controller (240 Volt)	X	X	X	X
17	988218-005	Controller (240 Volt)	X	X	X	X
18	170422	Lamp	X	X	X	X
19	170421	Lamp cord complete	X	X	X	X
20	170414	Set screw (2)	X	X	X	X
21	170415	Washer (2)	X	X	X	X
22	170412	Nut (2)	X	X	X	X
23	170416	Set screw	X	X	X	X
24	170413	Lamp bracket	X	X	X	X
25	170430	Lamp cord guide set screw	X	X	X	X
26	170429	Lamp cord guide	X	X	X	X
27	170435	Set screw (2)	X	X	X	X
28	170434	Receptacle	X	X	X	X
29	170433	Receptacle insulation	X	X	X	X
30	170427	Terminal bracket	X	X	X	X
31	170428	Set screw (2)	X	X	X	X

SEE: TABLE OF TERRITORIES FOR MOTORS AND CONTROLLER

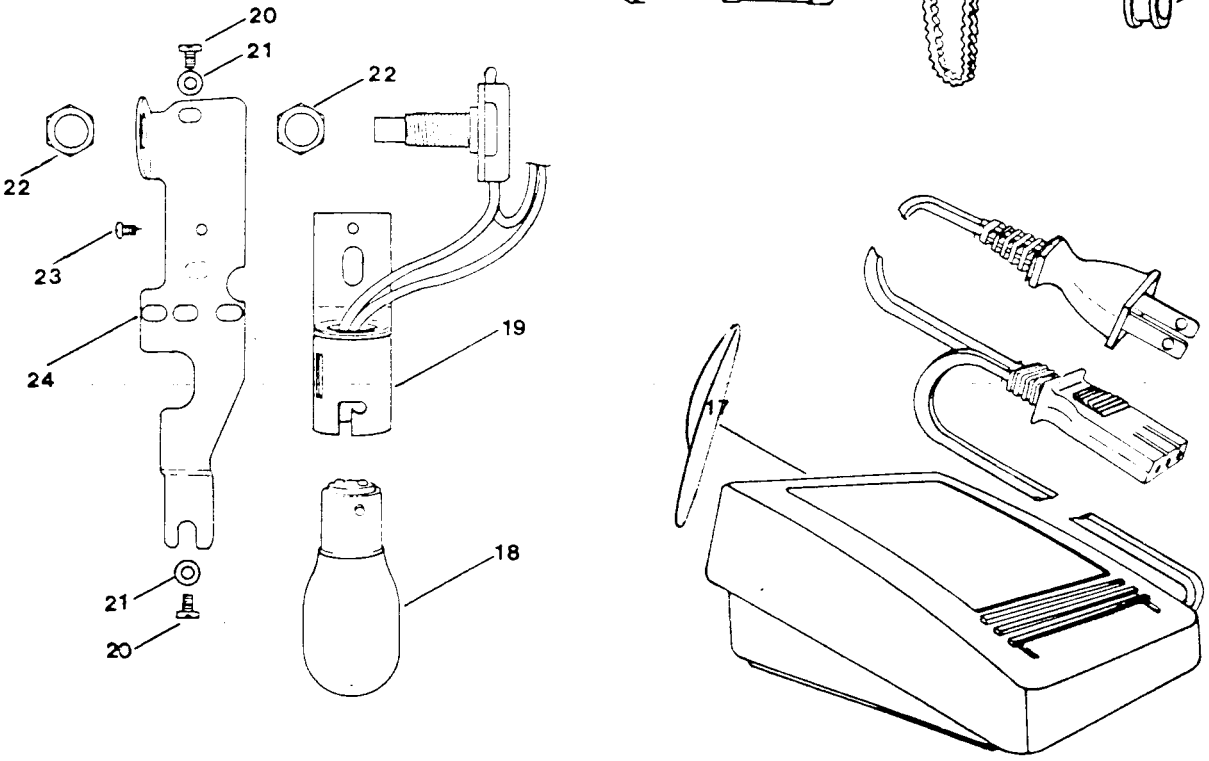
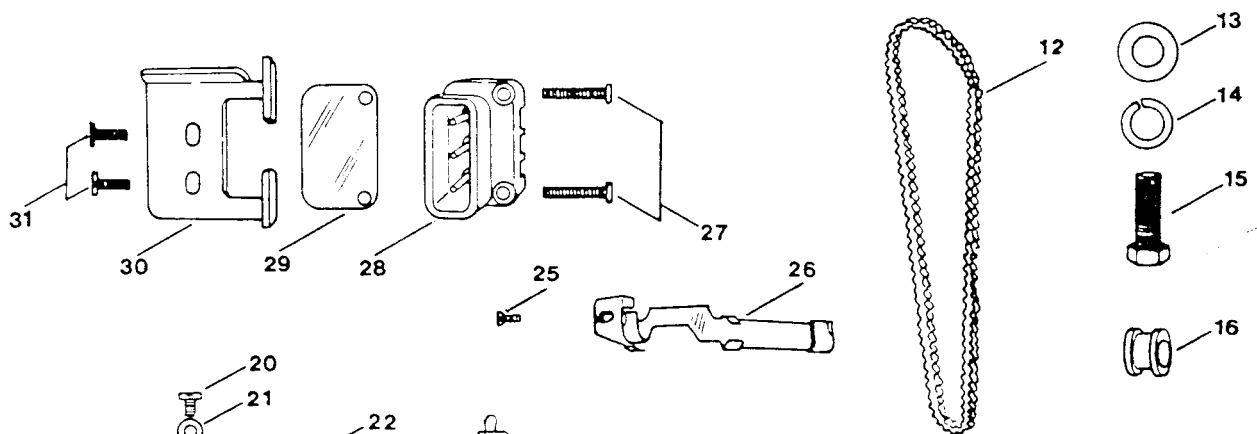
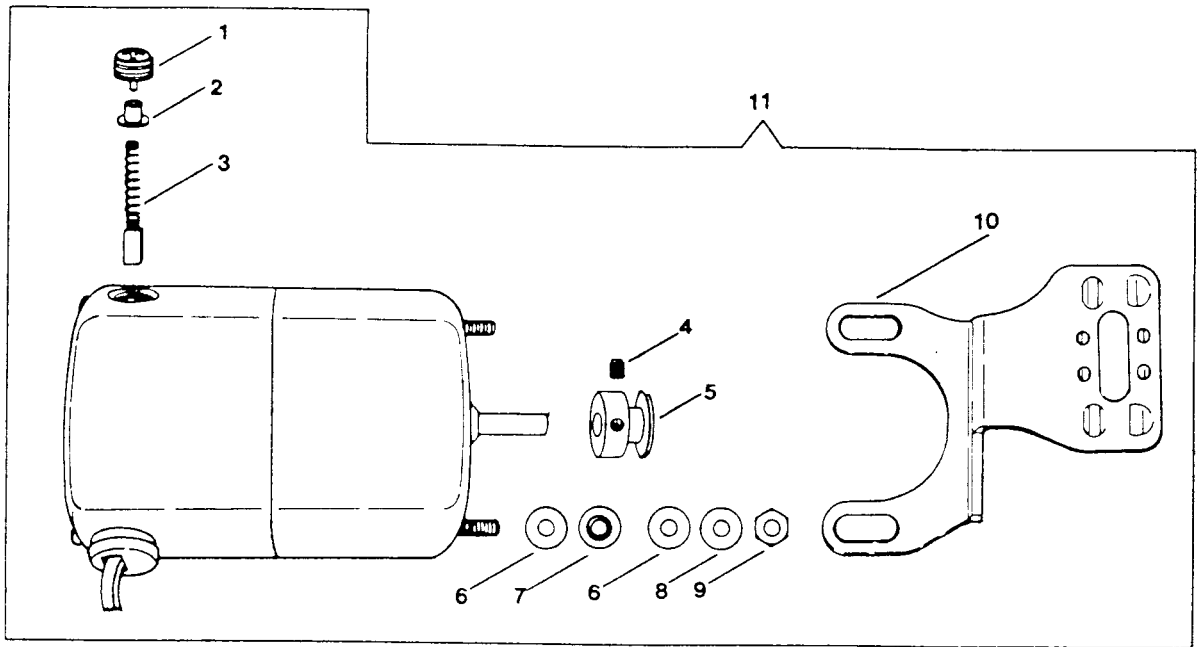

From the library of: Diamond Needle Corp